



a journal of the *Society for Music Theory*

## MTO 17.1 Examples: Temperley, Cadential IV in Rock

(Note: audio, video, and other interactive examples are only available online)

<http://www.mtosmt.org/issues/mto.11.17.1/mto.11.17.1.temperley.php>

### Example 1. The Landini Cadence



### Example 2. Five sectional cadences

#### A. Elvis Presley, "Hound Dog"

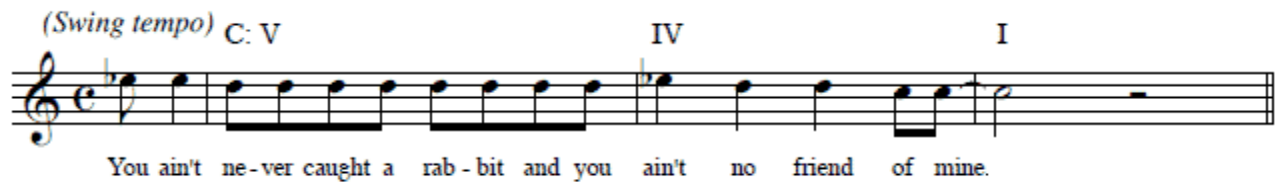

#### B. Beatles, "A Hard Day's Night"



C. Rolling Stones, "Honky Tonk Women"

Musical notation for the Rolling Stones' "Honky Tonk Women". The key signature is one sharp (F#) and the time signature is 4/4. The melody is written on a single treble clef staff. The lyrics are: Gim-me gim-me gim-me the honk-y tonk\_\_ blues. Chords are indicated above the staff: G:I, V, and I.

D. Tom Petty and the Heartbreakers, "Free Fallin'"

Musical notation for Tom Petty and the Heartbreakers' "Free Fallin'". The key signature is one flat (F) and the time signature is 4/4. The melody is written on a single treble clef staff. The lyrics are: Yeah I'm free Free fall - in'. Chords are indicated above the staff: F:I, IV, I V, I, IV.

E. Guns n' Roses, "Sweet Child O' Mine"

Musical notation for Guns n' Roses' "Sweet Child O' Mine". The key signature is three flats (Bb, Eb, Ab) and the time signature is 4/4. The melody is written on a single treble clef staff. The lyrics are: Woh - oh oh oh sweet love of mine. Chords are indicated above the staff: Db: V, bVII, and I.

**Example 3.** Creedence Clearwater Revival, "Proud Mary"

Musical notation for Creedence Clearwater Revival's "Proud Mary". The key signature is two sharps (F#, C#) and the time signature is 4/4. The melody is written on two treble clef staves. The lyrics are: Proud Ma-ry keep on burn - in' Roll - in' roll - in' roll - in' on the riv - er. Chords are indicated above the staff: D: vi and I.

**Table 1.** Distribution of chromatic roots in the RS 5x20 corpus (de Clercq & Temperley)

Root	Number of occurrences		Number of occurrences in pre-tonic position (proportion of total, excluding tonic)
	Proportion of total	Proportion of total, excluding tonic	
I	0.328	—	—
bII	0.005	0.007	0.010
II	0.036	0.053	0.041
bIII	0.026	0.038	0.017
III	0.019	0.028	0.005
IV	0.226	0.336	0.396
#IV/bV	0.003	0.004	0.002
V	0.163	0.241	0.269
bVI	0.040	0.059	0.071
VI	0.072	0.107	0.050
bVII	0.081	0.119	0.132
VII	0.004	0.006	0.005

**Table 2.** Chord transitions in the RS 5x20 corpus (de Clercq & Temperley).

Cells indicate the number of occurrences from one chord (the “antecedent”) to another (the “consequent”)

Cons Ant													
	I	bII	II	bIII	III	IV	#IV/ bV	V	bVI	VI	bVII	VII	
I	0	25	132	94	44	1052	2	710	104	302	470	16	
bII	31	0	0	0	2	0	0	0	0	0	0	12	
II	120	1	0	2	20	58	0	97	0	24	10	0	
bIII	50	6	6	0	0	64	2	2	67	0	41	0	
III	16	0	39	0	0	46	0	6	0	60	3	4	
IV	1162	14	30	98	45	0	4	514	57	72	90	4	
#IV/bV	7	0	0	6	0	10	0	0	0	0	0	0	
V	788	0	36	6	17	392	4	0	6	191	48	0	
bVI	208	0	1	20	0	22	6	22	0	10	78	0	
VI	144	0	87	0	32	260	0	124	21	0	3	0	
bVII	386	0	0	11	2	188	2	26	114	6	0	0	
VII	18	0	0	0	12	0	4	0	0	3	0	0	

**Table 3.** The RS 200 List, showing sectional cadences as identified by Temperley (DT) and Trevor de Clercq (TdC).

In every case where a sectional cadence was found, the pre-tonic harmony is indicated

<b>Title</b>	<b>Artist</b>	<b>DT</b>	<b>TdC</b>
1999	Prince	vi	vi <sup>7</sup>
A Change Is Gonna Come	Sam Cooke	-	vi
A Day in the Life	Beatles	-	-
A Hard Day's Night	Beatles	IV	IV
All Along the Watchtower	Jimi Hendrix	-	-
All Apologies	Nirvana	-	-
All I Have to Do is Dream	Everly Brothers	-	V
Anarchy in the U.K.	Sex Pistols	ii	ii
Back in Black	AC/DC	-	-
Be-Bop-a-Lula	Gene Vincent	-	IV
Be My Baby	Ronettes	-	-
Billie Jean	Michael Jackson	iv	iv
Bitter Sweet Symphony	Verve	-	-
Bizarre Love Triangle	New Order	-	-
Blitzkrieg Bop	Ramones	V	V
Blowin' in the Wind	Bob Dylan	V	V
Blue Suede Shoes	Carl Perkins	V	V
Blueberry Hill	Fats Domino	V	V
Bo Diddley	Bo Diddley	-	-
Bohemian Rhapsody	Queen	-	-
Born to be Wild	Steppenwolf	-	-
Born to Run	Bruce Springsteen	V	V
Both Sides Now	Joni Mitchell	V	Vsus4

Bridge over Troubled Water	Simon & Garfunkel	vii <sup>o</sup> <sub>2</sub> <sup>4</sup>	vii <sup>o7</sup>
Brown-Eyed Girl	Van Morrison	-	Van Morrison
California Dreamin'	Mamas & Papas	-	-
California Girls	Beach Boys	bvii <sup>7</sup>	bvii
California Love	2Pac	-	-
Cathy's Clown	Everly Brothers	V	V
Changes	David Bowie	ii	IV <sup>6</sup>
Come As You Are	Nirvana	-	-
Crazy	Patsy Cline	V	V
Crying	Roy Orbison	V	V
Da Doo Ron Ron	Crystals	V	V
Dancing in the Street	Martha and the Vandellas	-	-
Dancing Queen	ABBA	ii	ii
Dock of the Bay	Otis Redding	II	II
Don't Worry Baby	Beach Boys	-	-
Dream On	Aerosmith	-	-
Earth Angel	Penguins	V	V
Eight Miles High	Byrds	-	-
Eleanor Rigby	Beatles	bVI	-
Enter Sandman	Metallica	-	-
Every Breath You Take	Police	V	V
Everyday People	Sly and the Family Stone	-	-
Fake Plastic Trees	Radiohead	ii	ii <sup>7</sup>
Family Affair	Sly and the Family Stone	-	-
Fast Car	Tracy Chapman	-	-
Folsom Prison Blues	Johnny Cash	V	V

For What It's Worth	Buffalo Springfield	-	IV
Fortunate Son	Creedence Clearwater Revival	IV	IV
Foxy Lady	Jimi Hendrix	IV	-
Free Fallin'	Tom Petty and the Heartbreakers	V	V
Georgia on My Mind	Ray Charles	V	V
Gimme Shelter	Rolling Stones	-	-
Go Your Own Way	Fleetwood Mac	-	-
God Only Knows	Beach Boys	-	-
God Save The Queen	Sex Pistols	V	V
Good Golly, Miss Molly	Little Richard	IV	IV
Good Vibrations	Beach Boys	IV	-
Great Balls Of Fire	Jerry Lee Lewis	-	-
Hallelujah	Jeff Buckley	V	V
Heartbreak Hotel	Elvis Presley	V	V
Help	Beatles	-	-
Heroes	David Bowie	IVdom <sup>7</sup>	IV
Hey Jude	Beatles	V	V
Honky Tonk Women	Rolling Stones	V	V
Hot Stuff	Donna Summer	V	v
Hotel California	Eagles	-	-
Hound Dog	Elvis Presley	IV	IV
House of the Rising Sun	Animals	V	V
I Believe I Can Fly	R Kelly	-	-
I Can't Make You Love Me	Bonnie Raitt	-	-
I Can't Stop Loving You	Ray Charles	V	V
I Fought the Law	Bobby Fuller Four	V	V
I Got You (I Feel Good)	James Brown	IV	IV

I Heard It Through the Grapevine	Marvin Gaye	IV	IV
I Only Have Eyes for You	Flamingos	-	-
I Saw Her Standing There	Beatles	V	V
I Still Haven't Found What I'm Looking For	U2	IV	IV
I Walk the Line	Johnny Cash	V	V
I Wanna Be Sedated	Ramones	-	-
I Want to Hold Your Hand	Beatles	V	V
I Want You Back	Jackson Five	-	-
I'm So Lonesome	Hank Williams	V	V
I'm Waiting for the Man	Velvet Underground	IV	IV
Imagine	John Lennon	V	-
In Bloom	Nirvana	IV	IVdom <sup>7</sup>
In My Life	Beatles	iv	iv
In the Midnight Hour	Wilson Pickett	IV	IV
In the Still of the Night	Five Satins	V	V
It's a Man's World	James Brown	V	V
I've Been Loving You	Otis Redding	V	V
Jailhouse Rock	Elvis Presley	-	-
Johnny B. Goode	Chuck Berry	V	V
Jumpin' Jack Flash	Rolling Stones	IV	IV
Kashmir	Led Zeppelin	-	-
Layla	Derek and the Dominoes	-	-
Let It Be	Beatles	-	IV
Let's Get it On	Marvin Gaye	-	-
Let's Stay Together	Al Green	-	-
Light My Fire	Doors	-	-
Like a Rolling Stone	Bob Dylan	V	V

Little Red Corvette	Prince	-	-
Living for the City	Stevie Wonder	V	V
London Calling	Clash	-	bVII
Long Tall Sally	Little Richard	IV	IV
Lose Yourself	Eminem	-	-
Loser	Beck	-	-
Losing My Religion	REM	bVI	bVII
Louie Louie	Kingsmen	IV	IV
Love and Happiness	Al Green	V <sup>7</sup>	V <sup>7</sup>
Love Will Tear Us Apart	Joy Division	-	-
Lust for Life	Iggy Pop	V	V
Maggie May	Rod Stewart	V	IV
Maybellene	Chuck Berry	V	V
Me and Bobby McGee	Janis Joplin	V	V
Mr. Tambourine Man	Bob Dylan	V	V
Mr. Tambourine Man	Byrds	V	V
My Generation	Who	bVII	-
My Girl	Temptations	-	-
Mystery Train	Elvis Presley	IV	IV
No Woman, No Cry	Bob Marley & the Wailers	IV	IV
Norwegian Wood	Beatles	v	-
Not Fade Away	Buddy Holly	-	-
Nothing Compares 2 U	Sinead O'Connor	-	-
Nuthin' But a 'G' Thang	Dr. Dre	-	-
One	U2	IV	-
Paint it Black	Rolling Stones	-	-



Papa Was a Rolling Stone	Temptations	-	-
Papa's Got a Brand New Bag	James Brown	IV	dom <sup>7</sup> IV
Paranoid Android	Radiohead	-	-
People Get Ready	Impressions	V <sup>11</sup>	V <sup>9</sup> sus4
Please Please Please	James Brown	V	V
Proud Mary	Creedence Clearwater Revival	-	-
Purple Haze	Jimi Hendrix	-	-
Purple Rain	Prince	V	V
Rave On	Buddy Holly	V	V
Redemption Song	Bob Marley	V	V
Respect	Aretha Franklin	IV	-
Ring of Fire	Johnny Cash	V	V
River Deep - Mountain High	Tina Turner	-	-
Rock and Roll Music	Beatles	V	V
Rock Around the Clock	Buddy Holly & Crickets	V	V
Rock Lobster	B-52s	-	-
Rockin' in the Free World	Neil Young	-	-
Roll Over Beethoven	Chuck Berry	IV	IV
Sabotage	Beastie Boys	-	-
Satisfaction	Rolling Stones	IV	-
September Gurls	Big Star	-	-
Shake Rattle and Roll	Big Joe Turner	IV	IV
She Loves You	Beatles	V	-
Should I Stay or Should I Go	Clash	V	V
Shout	Isley Brothers	-	-
Smells Like Teen Spirit	Nirvana	-	-

Sounds of Silence	Simon & Garfunkel	bVII	bVII
Stairway To Heaven	Led Zeppelin	-	-
Stand by Me	Ben E. King	V	V
Strawberry Fields Forever	Beatles	IV	IV
Summer Babe	Pavement	-	-
Summertime Blues	Eddie Cochran	-	-
Sunshine of Your Love	Cream	-	-
Superstition	Stevie Wonder	V	V
Suspicious Minds	Elvis Presley	-	-
Sweet Child O' Mine	Guns N' Roses	bVII	bVII
Sympathy for the Devil	Rolling Stones	V	V
Take Me to the River	Al Green	-	-
Tangled Up in Blue	Bob Dylan	IV	IV
Tears in Heaven	Eric Clapton	V	V <sup>sus4</sup>
That'll Be the Day	Buddy Holly	V	V
That's All Right	Elvis Presley	V	V
The Boxer	Simon & Garfunkel	V	-
The Message	Grandmaster Flash	-	-
The Times They Are A-Changin'	Bob Dylan	V	V
The Weight	The Band	IV	IV
Thunder Road	Bruce Springsteen	V	-
Tracks of My Tears	Smokey Robinson	IV	V
Tutti Frutti	Little Richard	-	-
Up on the Roof	Drifters	-	-
Voodoo Child	Jimi Hendrix	bVII	bVII
Walk On By	Dionne Warwick	IV	IV

Waterloo Sunset	Kinks	-	-
What'd I Say	Ray Charles	-	-
What's Going On	Marvin Gaye	-	-
When a Man Loves a Woman	Percy Sledge	V	V
When Doves Cry	Prince	-	bVII
While My Guitar Gently Weeps	Beatles	-	-
Whiter Shade of Pale	Procol Harum	IV	IV
Who Do You Love	Bo Diddley	-	-
Whole Lotta Love	Led Zeppelin	bVII	bVII
Whole Lotta Shakin' Goin On	Jerry Lee Lewis	IV	IV
Will You Love Me Tomorrow	Shirelles	V	V
With or Without You	U2	-	-
Won't Get Fooled Again	Who	IV	IV
Yesterday	Beatles	IV	IV
You Can't Always Get What You Want	Rolling Stones	IV	IV
You Really Got Me	Kinks	-	-
You Send Me	Sam Cooke	V	V
You've Lost That Lovin' Feelin'	Righteous Brothers	bVII	IV
Your Song	Elton John	ii <sup>6</sup> <sub>5</sub>	-

**Table 4.** Pre-tonic harmonies in sectional cadences in the RS 200 list, as labeled in Table 3 (from Temperley’s data only), in descending order of frequency. The middle column shows the number of songs in which each harmony occurs in pre-tonic position in a sectional cadence; the rightmost column shows these counts as a percentage of the *total* number of songs (including those with no sectional cadence). Chords are identified by root only

Chord	Number of songs	Percent of total
V	64	32%
IV	37	18.5%
bVII	7	3.5%
II	6	3%
bVI	2	1%
VI	1	0.5%
VII	1	0.5%
Total	118	59%

**Example 4.** Heart, “Barracuda”

The image displays a musical score for the song "Barracuda" by Heart, focusing on three lines of music. The key signature is three sharps (F#, C#, G#) and the time signature is common time (C). The lyrics are: "You're ly - in' so low in the weeds I bet you're go-nna am-bush me You have me down down down down on my knees Now would ya Bar - ra - cu - da".

Chord annotations above the notes indicate pre-tonic harmonies in sectional cadences:

- Line 1 (measures 28-31): E: bVI (measure 28), i (measure 30), bVI (measure 31).
- Line 2 (measures 32-34): i (measure 32), bVII (measures 33-34).
- Line 3 (measures 35-38): IV (measures 35-36), I (measures 37-38).

**Example 5.** The essential features of the plagal stop cadence

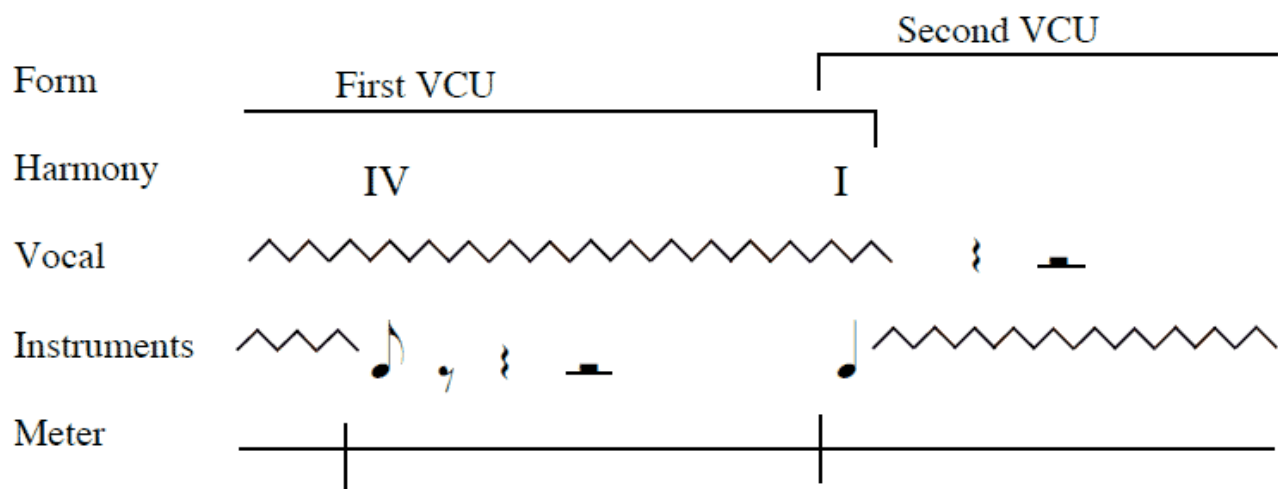

**Table 5.** Songs with plagal stop cadences

Title	Artist	Year
Love Me Do	Beatles	1962
The Last Time	Rolling Stones	1965
Back in the USSR	Beatles	1968
The Weight	The Band	1968
You Can't Always Get What You Want	Rolling Stones	1969
Bargain	The Who	1971
Won't Get Fooled Again	The Who	1971
Rock and Roll	Led Zeppelin	1971
Rikki Don't Lose That Number	Steely Dan	1974
Golden Years	David Bowie	1975
Magic Man	Heart	1976
Barracuda	Heart	1977
Everybody Wants You	Billy Squier	1982
Faithfully	Journey	1983
I Want a New Drug	Huey Lewis & News	1984
(Don't Go Back to) Rockville	REM	1984
When I Come Around	Green Day	1994
High and Dry	Radiohead	1995
Name	Goo Goo Dolls	1995
Redemption Day	Sheryl Crowe	1996
How's it Gonna Be	Third Eye Blind	1997
Blue on Black	Kenny Wayne Shepherd	1997
She's So High	Tal Bachman	1999
My Stupid Mouth	John Mayer	2001
One Hundred Years	Five for Fighting	2004
Home	Daughtry	2006

**Example 6.** Survivor, “Eye of the Tiger”

Chord symbols: C: iv, bIII6, bVII, iv, bIII6, bVI, i

Lyrics: And the last known sur-vi - vor stalks his prey in the night And he's watch - ing us all in the eye of the ti - ger

**Example 7.** Huey Lewis and the News, “I Want a New Drug”

Chord symbols: A: V, bIII, bVI (IV/bIII?), bIII, IV, I, bVII, IV

Lyrics: One that won't make me ner - vous Won-dering what to do One that makes me feel like I feel when I'm with you When I'm a - lone with you

**Example 8.** Led Zeppelin, “Whole Lotta Love”

*Slow and very free tempo*  
E: (I)

Way down in - side\_\_\_\_\_ Wo-man You\_\_\_\_\_ need it

IV *a tempo* I

Love\_\_\_\_\_

**Table 6.** Songs with grand plagal cadences

Title	Artists	Year
Somebody to Love	Jefferson Airplane	1967
Get Back	Beatles	1969
Whole Lotta Love	Led Zeppelin	1969
Stairway to Heaven	Led Zeppelin	1971
Long Train Runnin'	Doobie Brothers	1973
Say You Love Me	Fleetwood Mac	1975
Back in Black	AC/DC	1980

**Example 9.** Led Zeppelin, “Stairway to Heaven”

A: bIII      bVII6      IV

(bIII)      IV      (bIII      bVII6)      i

**Example 10.** Crosby, Stills, & Nash, “Wasted on the Way”

D: IV V I vi

So much wa - ter mov - ing Un - der - neath the bri -

IV V IV I

dge Let the wat - er come and car - ry us a - way

**Example 11.** Doobie Brothers, “Long Train Runnin’” (A) End of choruses 1-4; (B) end of fifth chorus

A.

G: bVI V<sup>6</sup><sub>4</sub>-----5 3 i

With - out lo - - - - ve

B.

bVI V<sup>6</sup><sub>4</sub>-----5 3 iv *Very free* i *a tempo*

With - out lo - - ve Ooh Where would you be now



**Example 12.** Alice in Chains, “No Excuses”

Musical score for Alice in Chains' "No Excuses". The score is in 4/4 time and B-flat major. It consists of two staves of music with lyrics underneath. The first staff has lyrics: "Ev-ery day \_\_\_ it's some - thing hits \_\_\_ me all \_\_\_ so cold \_\_\_ You". The second staff has lyrics: "find me sitt-ing by \_\_\_ my - self \_\_\_ No ex - cuse - s that I know \_\_\_". Chord symbols are placed above the notes: Bb: bVI, bVII, I, bVI, bVII, IV, I.

**Example 13.** Wallflowers, “One Headlight”

Musical score for Wallflowers' "One Headlight". The score is in 4/4 time and D major. It consists of two staves of music with lyrics underneath. The first staff has lyrics: "Me and Cin - der - ell - a put it all to - geth - er We can drive it ho - me". The second staff has lyrics: "With one head - light". Chord symbols are placed above the notes: D: IV, I, ii, V, IV, I.

**Example 14.** Three uses of the deceptive IV at the end of the VCU (“X” represents an unspecified harmony before the IV)

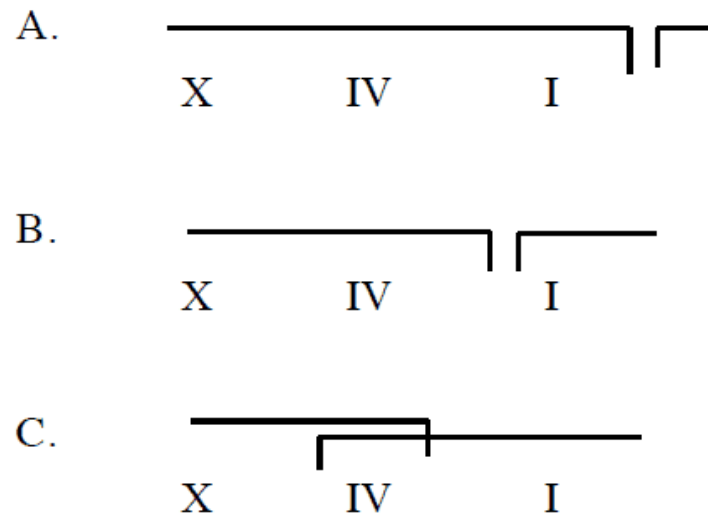

**Example 15.** Nazareth, “Love Hurts”



The musical notation shows a single staff in G major (one sharp) and common time. The lyrics are "Love hurts Ooh Love hurts". The chords are labeled above the staff: G: (G major), I (G major),  $bVII$  (F major), IV (C major), and I (G major). The melody consists of quarter notes: G4, A4, B4, C5, B4, A4, G4. The lyrics "Love hurts" are under the first two notes, "Ooh" is under the next two notes, and "Love hurts" is under the final two notes. A slur covers the "Ooh" and the first "Love hurts". A fermata is placed over the final G4 note.

**Example 16.** The Who, “Bargain”

Chord symbols: Bb, bVI, bVII, IV, I

Vocal line: I'd call it a bar - gain The best I e - ver had

Piano line: The best I e - ver had

**Example 17.** Recomposition of the Who's “Bargain”

Chord symbols: Bb, bVI, bVII, I

Vocal line: I'd call it a bar - gain The best I e - ver had

**Example 18.** A conventional common-practice progression

Chord symbols: C: I, V6/5, I, ii6, V  $\begin{smallmatrix} 6-4 \\ 5-3 \end{smallmatrix}$ , vi, ii6, viio6/ii, ii, V  $\begin{smallmatrix} 6-4 \\ 5-3 \end{smallmatrix}$ , I

**Example 19.** Billy Joel, “Just the Way You Are”

The image shows a single line of musical notation in treble clef, key of D major (one sharp), and common time (C). The melody consists of the following notes: a quarter rest, a quarter note D4, a quarter note E4, a quarter note F#4, a quarter note G4, a quarter note A4, a quarter note B4, a quarter note A4, a quarter note G4, a quarter note F#4, a quarter note E4, and a half note D4. The lyrics "I'll take you just the way you are" are written below the notes. Above the staff, the chord symbols "D: ii", "V11", and "I" are positioned above the first, second, and final notes respectively.